

MIL-E-1/1428C(NAVY)
12 July 1965
 SUPERSEDING
 MIL-E-1/1428B(NAVY)
 14 October 1963
 (See Note 21)

MILITARY SPECIFICATION SHEET

ELECTRON TUBE, THYRATRON, HYDROGEN

TYPE 7621

The complete requirements for procuring the electron tube described herein shall consist of this document and the latest issue of MIL-E-1.

DESCRIPTION: Ceramic-metal hydrogen thyatron with internal reservoir

DIMENSIONS: See figure 1

MOUNTING POSITION: Any

MOUNTING ARRANGEMENT: By cathode flange, see figure 1

ABSOLUTE-MAXIMUM RATINGS:

Parameter:	Ef	epy	epx	Ebb	Ip	egy	ib
Unit:	Vac	kv	kv	Vdc	Aac	v	a
Maximum:	6.3+7.5%	8 (Note 1)	8 (Note 2)	---	2 (Note 4)	---	90 (Note 3)
Minimum:	6.3-7.5%	---	5% epy	300	---	175	---
<u>TEST CONDITIONS:</u>	6.3	8	---	---	---	130	---

ABSOLUTE-MAXIMUM RATINGS:

Parameter:	Ib	tk	Pb	TA	$\frac{dik}{dt}$	pr	Cooling	tj	Ecc
Unit:	mAdc	sec	---	°C	a/us	pps	---	us	Vdc
Maximum:	100	---	2.7×10^9	+125	1000	---	(Note 5)	0.010	---
Minimum:	---	90	---	-65	---	---	---	---	0
<u>TEST CONDITIONS:</u>	---	90	---	Ambient	---	4000	---	---	0

7621

FSC 5960

MIL-E-1/1428C(NAVY)

REQUIREMENT OR TEST:

GENERAL

3.1.1 Performance Section 5 Preparation for Delivery (Note 19)

3.2 Qualification - Required (Note 17) E-50.2 Holding period - t=96 hrs. (min)

METHOD OR PARA.	REQUIREMENT OR TEST	CONDITIONS	SYMBOL	LIMITS		UNIT
				MIN.	MAX.	
	<u>Qualification inspection (Note 18)</u>					
1031	Variable-frequency vibration	No voltages (Note 16)	---	---	---	---
1041	Shock	250G; no voltages	---	---	---	---
---	Shock test end points	Operation (1)	egy	---	175	v
		Critical anode voltage for conduction.	Ebb	---	250	v
		Time jitter	tj	---	0.01	us
	<u>Quality conformance inspection, part 1</u>					
Appendix D, 20(a)	Visual and mechanical inspection criteria	---	---	---	---	---
3146	Instantaneous start	epy=8.0 kv (min) Ef=6.8 Vac (Notes 6 & 7)	---	---	---	---
3246	Operation (1)	epy=8.0 kv (min) t=300 sec Ef=5.8 Vac tk=90 sec (Notes 6,8, & 9)	---	---	---	---
3241	Heater current	Ef=6.3 Vac	If	2.2	3.5	Aac

METHOD OR PARA.	REQUIREMENT OR TEST	CONDITIONS	SYMBOL	LIMITS		UNIT
				MIN.	MAX.	
	<u>Quality conformance inspection, part 1 continued</u>					
3251	Emission	ik=90 a (min) prf=60 pps \pm 10% tp=5.0 us \pm 10% tr=0.5 us max Ef=5.8 Vac (Note 10)	egk	---	200	v
3246	Critical anode voltage for conduction	Ef=5.8 Vac (Notes 6 & 15)	Ebb	---	200	Vdc
	<u>Quality conformance inspection, part 2</u>					
3256	Anode delay time	Operation (1) t=30 sec (Note 11)	tad	---	0.4	us
3256	Anode delay time drift	Anode delay time; (Note 12)	Δ tad	---	0.15	us
3261	Time jitter	Operation (1); (Note 13) Ef=5.8 Vac tk=90	tj	---	0.010	us
3246	Operation (2)	t=5 hr; TA=90°C Ef=6.8 Vac (Notes 6,8,9, & 20)	egy	---	175	v
	<u>Quality conformance inspection, part 3</u>					
4.7	Life test	Ef=6.3 Vac (Notes 6 & 14)	t	200	---	hrs

MIL-E-1/1428C (NAVY)

METHOD OR PARA.	REQUIREMENT OR TEST	CONDITIONS	SYMBOL	LIMITS		UNIT
				MIN.	MAX.	
4.7.3	<u>Quality conformance inspection, part 3 continued</u> Life test end points	Operation (1) except Note 9 egy=140 v (max)	---	---	---	---
		Critical anode voltage for conduction egy=140 v (max)	Ebb	---	250	Vdc
		Anode delay time tad egy=140 v (max)	tad	---	0.5	us
1136	Container drop					

NOTES:

1. Instantaneous starting is permissible. The maximum permissible epy is 8.0 kv and shall not be attained in less than 0.04 second.
2. In pulsed operation, the peak inverse voltage, exclusive of a spike of 0.05 us max. duration, shall not exceed 2.5 kv during the first 25 us following the anode pulse.
3. The driver pulse, measured at the tube socket with thyatron grid disconnected shall have the following characteristics: epy=175 v (min), tr=0.25 us (max), grid pulse duration tp=1.0 us (min). Impedance of drive circuit=1200Ω (max).
4. For hydrogen thyatron applications using essentially rectangular pulses, Ip shall be computed as the square root of the product Ib x ib.
5. Forced air cooling directed on the anode or envelope is permissible, depending upon operating conditions.
6. The tube shall be operated in the test circuit shown on figure 2. Tests performed at repetition rates less than resonant rates shall be made with a hold-off diode in the charging circuit. The circuit constants shall be chosen under resonant charging conditions so that epy=8.0 kv; ib=90 a (min); dik/dt=1,000 a/us (min); tp=0.12 ± 0.012 us; prr=4,000 pps (min).

WARNING: These conditions are specified only for the purpose of determining circuit constants. The actual operating voltage and repetition rates for each test are specified in the conventional manner under the particular conditions or under the general test conditions, as the case may be.

NOTES - Continued

6. (Continued) Grid pulse as measured at tube socket with thyatron disconnected shall have the following characteristics: $t_r=0.25$ us (max) (26-70 percent points), $t_p=1.0$ us (max) (70 percent point). The internal impedance of the driver shall be 1200 ohms (min).
7. This test shall be the first test performed after a 96 hour holding period. The tube shall operate satisfactorily on push-button starting within three attempts when the anode voltage (epy) is applied to the tube under test in such a manner as to rise from 0 to 8.0 kv (min) within 0.03 second. The intervals between successive attempts to instantaneously start the tube shall be not less than 10 nor more than 30 seconds. Any tube failing to start within three attempts shall be considered a failure.
8. The tube shall operate continuously without evidence of arcbback.
9. There shall be no evidence of anode heating during this test.
10. The positive pulse shall be applied to the grid of the tube. The voltage between grid and cathode shall be measured not more than 2.5 us after the beginning of the current pulse. The plate shall be floating.
11. Anode delay time (t_{ad}) is the time interval between the rising portion of the grid pulse which is 26 percent of the maximum unloaded pulse amplitude and the point where anode conduction takes place.
12. During the interval between 30 and 90 seconds of the anode delay time test, the change in anode delay time (Δt_{ad}) relative to the t_{ad} value observed on the anode delay time test shall not exceed the value specified herein.
13. The variation in firing time (t_j) shall be measured at 50 percent of pulse amplitude and shall be not greater than the amount specified herein.
14. During every 50 ± 8 hours of life test operation, the life test shall be shut off for 60 minutes (min) and then tested for life test end points.
15. This test shall be conducted within 60 seconds after operation (1) test.
16. There shall be no pronounced resonance in the range specified in method 1031.
17. The activity responsible for the qualified products list is the Bureau of Ships, Department of the Navy, Washington, D. C. 20360, and information pertaining to qualification of products may be obtained from that activity. Application for Qualification tests shall be made in accordance with "Provisions Governing Qualification." (Copies of "Provisions Governing Qualification" may be obtained upon application to Commanding Officer, Naval Supply Depot, 5801 Tabor Avenue, Philadelphia, Pennsylvania 19120.)

MIL-E-1/1428C (NAVY)

NOTES - Continued:

18. These tests are performed only during qualification inspection; however, qualification inspection shall consist of all tests listed on this specification sheet and the applicable tests of MIL-E-1.
19. Preservation, packaging and packing. - Unless otherwise specified in the contract or order, preservation, packaging and packing shall be as follows:
 - (a) Preservation and packaging shall be sufficient to afford adequate protection against corrosion and deterioration during shipment from the supply source to the using activity and until installation.
 - (b) Packing shall be accomplished in a manner which will insure acceptance and protection against physical or mechanical damage during direct shipment from the supply source to the using activity.
20. The tube shall operate satisfactorily at the ambient temperature specified herein at operation (1) conditions for a total of five consecutive hours with no more than three kickouts. This test shall be performed on a minimum of four tubes on an annual basis.
21. CHANGES FROM PREVIOUS ISSUE. THE EXTENT OF CHANGES (DELETIONS, ADDITIONS, ETC.) PRECLUDE THE ANNOTATION OF THE INDIVIDUAL CHANGES FROM THE PREVIOUS ISSUE OF THIS DOCUMENT.

Preparing activity:
Navy - SH
(Project 5960-N617(SHIPS))

MIL E 1/1428C (NAVY)

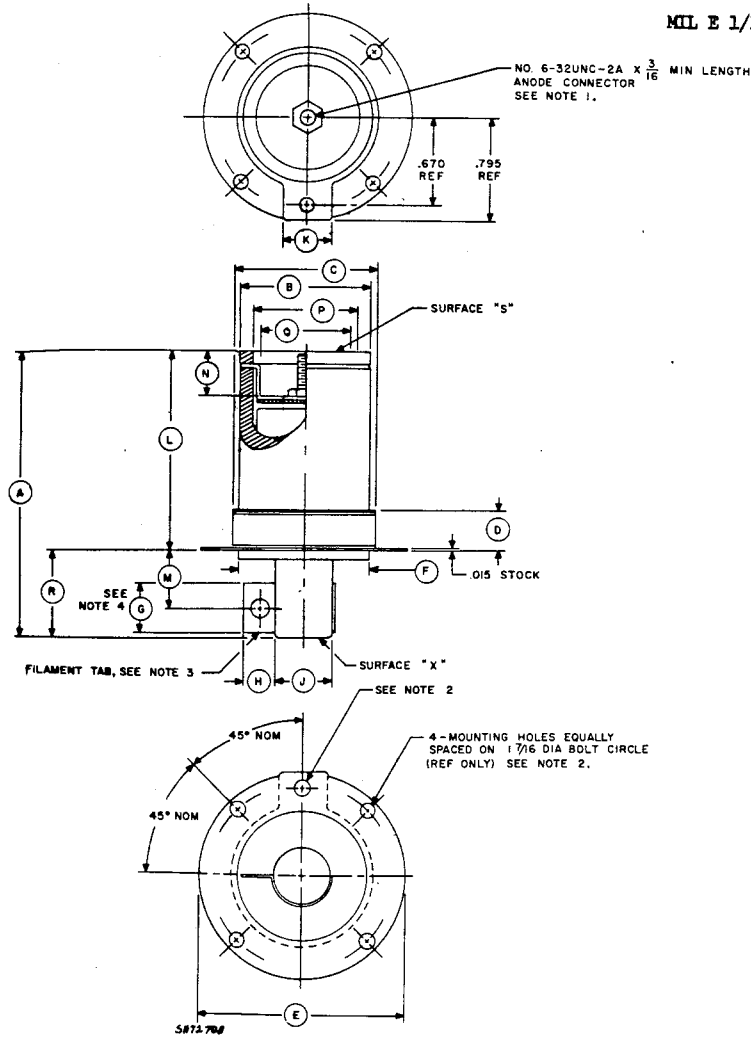

NOTES:

- 1 ANODE CONNECTOR SHALL NOT EXTEND ABOVE SURFACE "S"
- 2 ALL MOUNTING HOLES, INCLUDING GRID AND FILAMENT TAB HOLES, SHALL CLEAR NO. 4 SCREWS, (.120 DIA HOLES).
- 3 WRAP OF FILAMENT TAB ON PROTECTOR CUP OPTIONAL, RIGHT OR LEFT SIDE.
- 4 TAB EDGE SHALL NOT EXTEND BEYOND SURFACE "X".
- 5 GRID AND FILAMENT TABS SHALL NOT INTERFERE WITH CATHODE FLANGE MOUNTING HOLES.

DIM	LIMITS	
	MIN.	MAX.
A	—	2.355
B	0.985 DIA	1.015 DIA
C	—	1.150 DIA
D	0.295	0.340
E	1.579 DIA	1.639 DIA
F	0.985 DIA	1.015 DIA
G	—	0.500
H	—	0.438
J	—	0.469 DIA
K	0.250	0.500
L	1.500	1.600
M	0.335	0.585
N	0.250	0.360
P	0.785	0.815
Q	0.650 DIA	0.710 DIA
R	—	0.700

Figure 1 - Outline dimensions of tube type 7621.

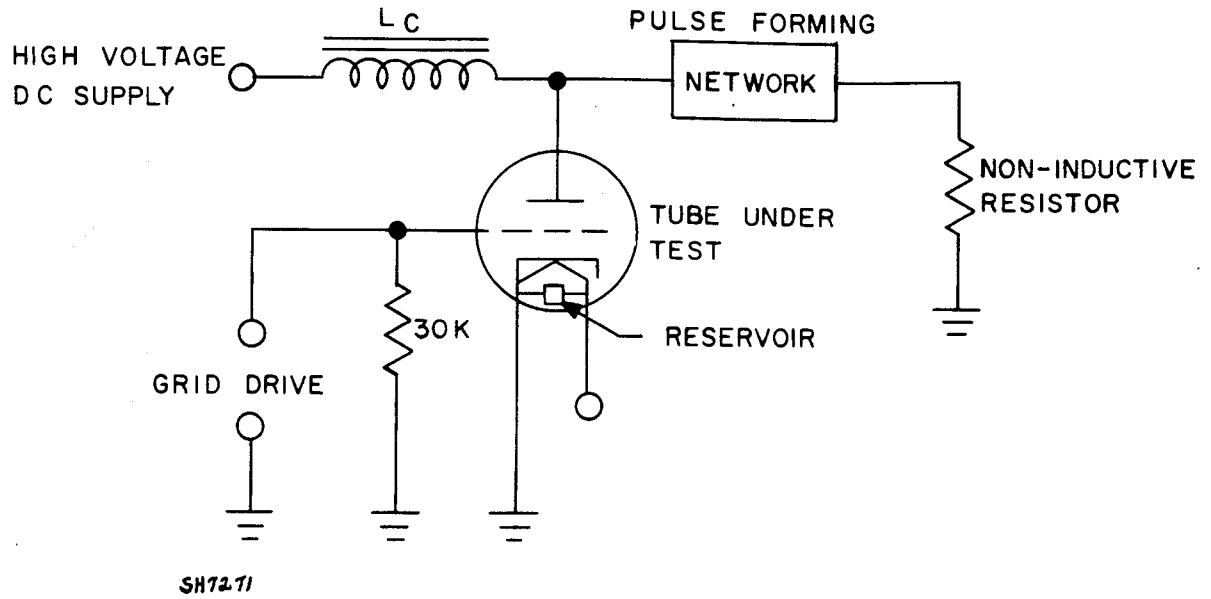

Figure 2 - Test circuit.