



NATIONAL

2M107A-605
2M107A-795
2M107A-825

7/1/92 PAGE 1 OF 10

870 WATT CW MAGNETRON - 2.45GHZ

THIS HIGHLY EFFICIENT, COMPACT CW MAGNETRON WITH INTEGRAL MAGNET IS SUITABLE FOR INDUSTRIAL APPLICATIONS AND CATERING OVENS. THESE MAGNETRONS MEET IEC SAFETY REGULATIONS AND BSI REGULATIONS FOR ELECTRICAL APPLIANCES. STABLE OPERATION IS POSSIBLE UNDER THE MOST SEVERE LOAD CONDITIONS. SPECIAL ATTENTION HAS BEEN PAID TO REDUCE STRAY RADIATION AND SUPPRESS HIGHER HARMONICS THAT MIGHT INTERFERE WITH SATELLITE TV TRANSMISSION. THE COMPACT MAGNETIC CIRCUIT HAS VERY LOW STRAY MAGNETIC FIELD. A MEASURING PROBE IS AVAILABLE WHICH ALLOWS A SIMPLE COLD MEASURING PROCEEDURE.

QUICK REFERENCE DATA

ELECTRICAL

Power Supply: L.C. stabilize halfwave doubler
Matched load condition:
Frequency: 2.46 GHz
Anode voltage: 4.1 kV
Anode current: 300 mA
Out power: 870W
Tube efficiency: 71.0%
Filament voltage: 3.3V
Filament current (operating): 10.5A

MECHANICAL

Dimensions: See outline drawings
Mounting position: Any
R.F. coupler: WR430 system
Magnetic system: Ferrite magnet, packaged
Cooling air flow: 800ℓ/min
Pressure drop: 4.9 mmAq
Weight (approx): 0.95 Kg (2.1 lbs)
Cold filament resistance: 0.047Ω
Pre-heating time: 0 sec.

1. ABSOLUTE MAXIMUM RATINGS

	Min.	Max.
Filament Voltage	2.80V	3.75V
Mean Anode Current	—	350mA
Peak Anode Current	—	1200mA
Anode Temterature (note #2)	—	250°C
(at the point indicated on the outline drawing)		
Load V.S.W.R. (note #3)	—	4
Storage Temperature	-35°C	+60°C

NATIONAL ELECTRONICS

A Division of Richardson Electronics, Ltd.
LaFox, IL 60147 • (708) 208-2300



NATIONAL

2M107A-605

2M107A-795

2M107A-825

7/1/92 PAGE 2 OF 10

VISUAL & MECHANICAL

1) Major Defects:

Any physical error, omission or dimensional deviation that affects the component function, fit or reliability.

2) Minor Defects:

Any physical error, omission or dimensional deviation that is purely aesthetic and does not affect function, fit or reliability.

NOTES

- #1. —If during the first snap-on there is evidence of a breakdown during 5 seconds of H.V. application, the test shall be repeated once and there should be no indication of breakdown again.
(I breakdown $\leq 400\mu\text{A}$, Series resistance $50\text{K}\Omega$)
- #2. —For power supply an L.C., single phase half wave doubler should used.
 - The filament voltage should be measured at the terminals.
 - The combination of transformer and capacitor should be chosen such that for nominal line voltage I_a mean = $300\text{mA} \pm 1\%$ and I_a peak 1020 to 1050mA.
 - It is recommended to use a 10-12KV avalanche diode as protection for capacitor and transformer.
 - For wave guide configuration and power supply, see page 7 and 10.
 - A water load of which the V.S.W.R. ≤ 1.1 over the frequency band 2425 MHz up to 2475 MHz shall be used.
 - Unless otherwise stated, limits apply for a tube within 15 seconds after application of voltages and at 25°C .
 - Before testing, the tubes should be "at room temperature" for at least four hours.
 - During test, the magnetron should be cooled with 800 1/min of forced air.
- #3. —After a minimum operation of 30 seconds under the specified conditions, the filament voltage is gradually decreased. The V_{fm} is the lowest V_f value at which the tube is still oscillating in the π mode.
- #4. —Starting with minimum operation of 30 seconds at nominal heater voltage and $I_a = 300\text{mA}$ for V.S.W.R ≤ 1.1 and at 2g distance from the tube, the V.S.W.R. must be increased by means of the Rieke transformer while the phase must be varied in the sink area.
The stability is the highest V.S.W.R. at which the tube is still oscillating in the correct π mode.
- #5. —Transients are measured on a storage scope during the period 0.5 to 2 seconds after switching on the anode voltage and filament voltage simultaneously.
- #6. —Design control tests only.

NATIONAL ELECTRONICS

A Division of Richardson Electronics, Ltd.

LaFox, IL 60147 • (708) 208-2300



NATIONAL

2M107A-605
2M107A-795
2M107A-825

7/1/92 PAGE 3 OF 10

2. TEST SPECIFICATION

2-1. ELECTRICAL TEST

TERM	Test Cond.					Limits				
	Vf(V)	Va(KV)	Ia(mA)	VSWR	Notes	Min.	Bogie	Max.	Unit	Notes
Breakdown Voltage	0	+ 10dc	—	—						#1
Cold start (Voltage transient)	3.3	—	300	≤ 1.1	#2			8	KV	#5
Frequency	3.3	—	300	≤ 1.1	#2	2450	2460	2470	MHz	
Peak Anode Voltage	3.3	—	300	≤ 1.1	#2	4.0	4.1	4.3	KV	
Efficiency	3.3	—	300	≤ 1.1	#2		71.0		%	
Mean Output Power (1)	3.3	4.1	300	≤ 1.1	#2		870		W	
Emission Stability			300	≤ 1.1	#2			2.5		#3
Stability	3.3				#4	4			VSWR	#6
Pulling Figure	3.3		300	1.3				10	MHz	#6

- #1. AVAILABLE IN TWO MECHANICAL OUTLINES
2M107A-795 MOUNTING & COOLING IN LINE WITH FASTON CONNECTOR.
2M107A-825 MOUNTING & COOLING NOT IN LINE WITH CONNECTOR.
(OTHER OUTLINES AVAILABLE UPON REQUEST)
- #2. IN AN ABNORMAL OPERATION, THE MAXIMUM ALLOWABLE TEMPERATURE FOR ANODE IS 280 DEGREES C, PROVIDED THAT THE DWELL TIME OF THE MAXIMUM TEMPERATURE DOES NOT EXCEED 2 HOURS OPERATION NOR 25 HOURS IN TOTAL.
- #3. THE LOAD CONDITION IN WHICH INSTANTANEOUS V.S.W.R. IS 4 - 10 MAY BE ALLOWED ONLY IF THE DWELL TIME UNDER THOSE CONDITIONS IS SHORT.

NATIONAL ELECTRONICS

A Division of Richardson Electronics, Ltd.
LaFox, IL 60147 • (708) 208-2300



NATIONAL

2M107A-605

2M107A-795

2M107A-825

7/1/92 PAGE 4 OF 10

3. WAVEGUIDE CONFIGURATION

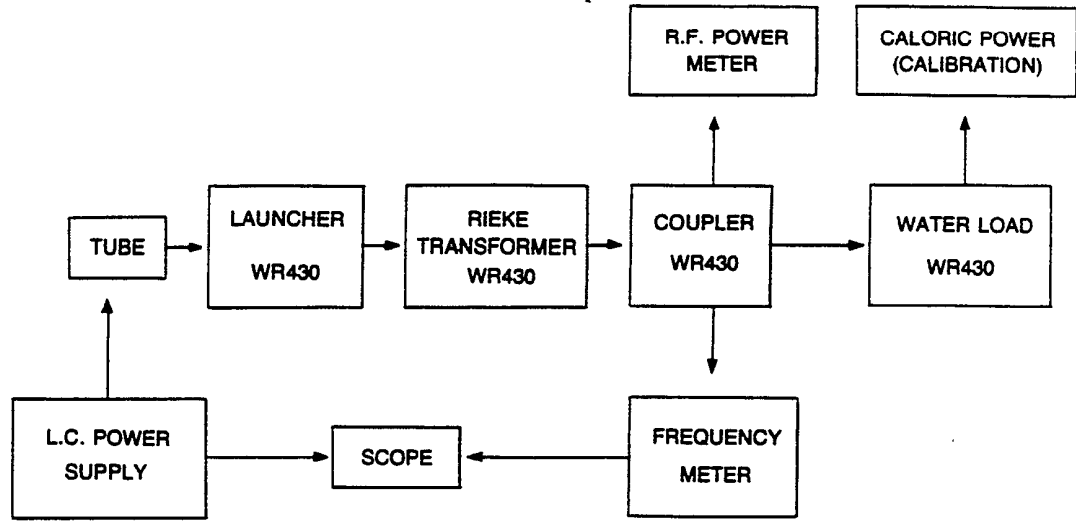

4. COUPLING SECTION WAVEGUIDE WR430

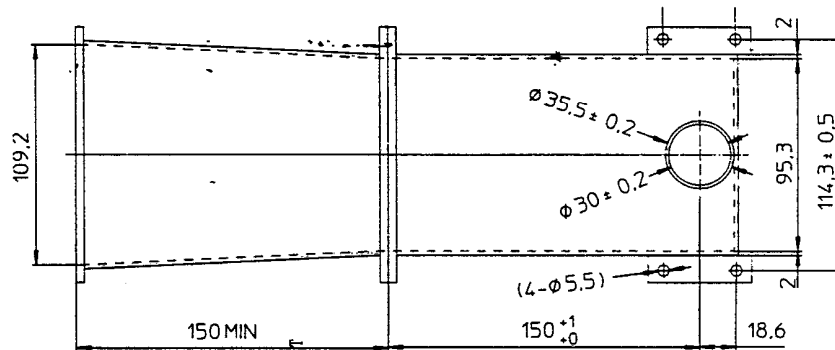

The flange mates with japanese standard BRJ-2

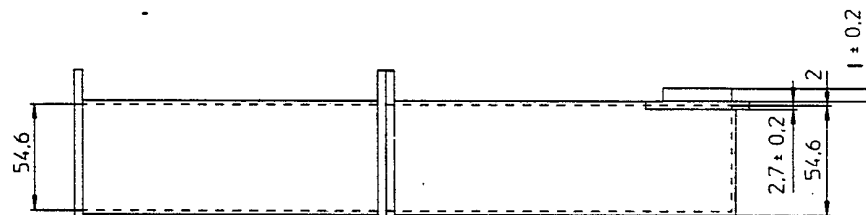

NATIONAL ELECTRONICS

A Division of Richardson Electronics, Ltd.

LaFox, IL 60147 • (708) 208-2300

5. RIEKE DIAGRAM IN WAVEGUIDE WR430

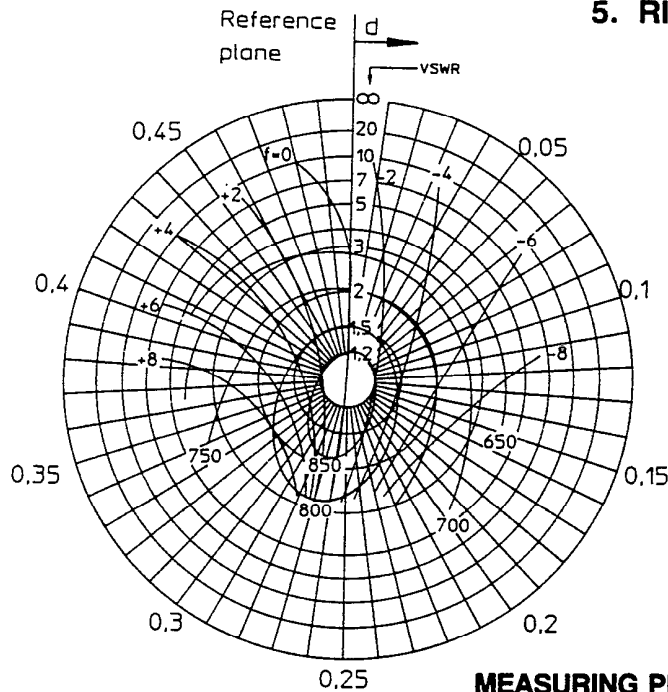

Power Supply: half-wave doubler L.C. type
 Filament Voltage 3.3V
 Average Anode Current 300mA
 Peak Anode Voltage 4.1KV
 Frequency at Matched Load 2460MHz
 d: distance of VSWR-minimum from reference plane towards load.

Diagram measured under cold condition.

MEASURING PROBE FOR OVEN DESIGN MEASUREMENTS

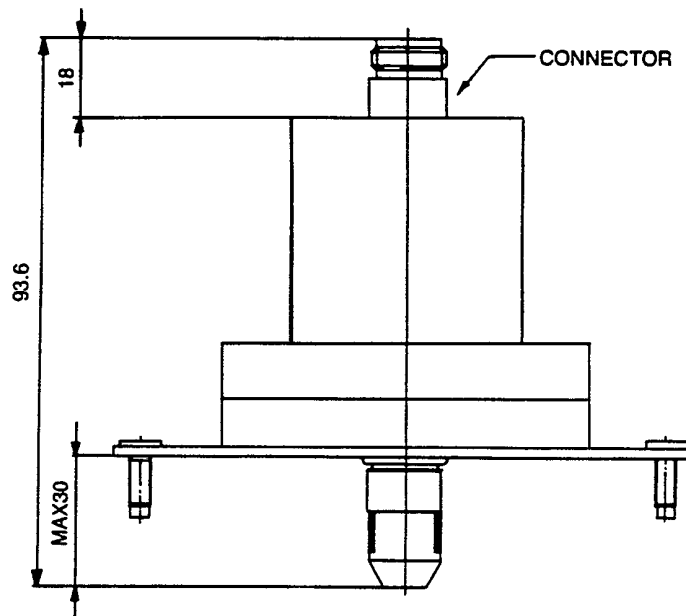

NATIONAL ELECTRONICS

A Division of Richardson Electronics, Ltd.
 LaFox, IL 60147 • (708) 208-2300



NATIONAL

2M107A-605
2M107A-795
2M107A-825

7/1/92 PAGE 6 OF 10

6. PERFORMANCE

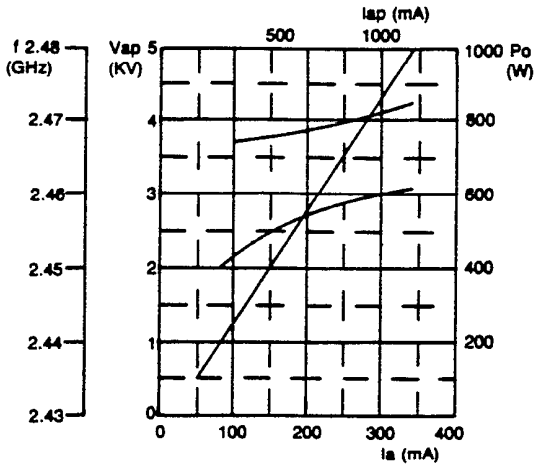

- Power supply: single phase half-wave doubler
- Filament voltage 3.3V
- Load VSWR 1.1 maximum
- Measured within 15 sec. after applying voltage

7. ANODE DISSIPATION VS. TEMPERATURE RISE OF THERMOSWITCH MOUNTING POSITION

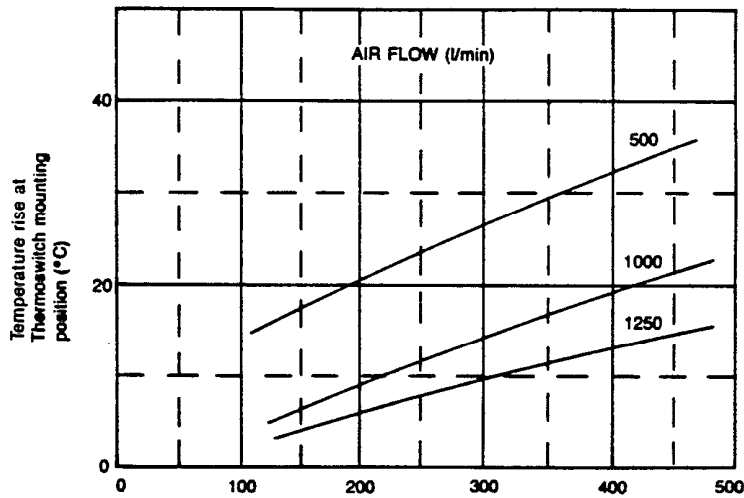

(Increase in temperature of thermoswitch mounting position above inlet air temperature, T, as a function of anode dissipation, W.)

NATIONAL ELECTRONICS

A Division of Richardson Electronics, Ltd.
LaFox, IL 60147 • (708) 208-2300



NATIONAL

2M107A-605
2M107A-795
2M107A-825

7/1/92 PAGE 7 OF 10

8. ANODE DISSIPATION VS. ANODE TEMPERATURE

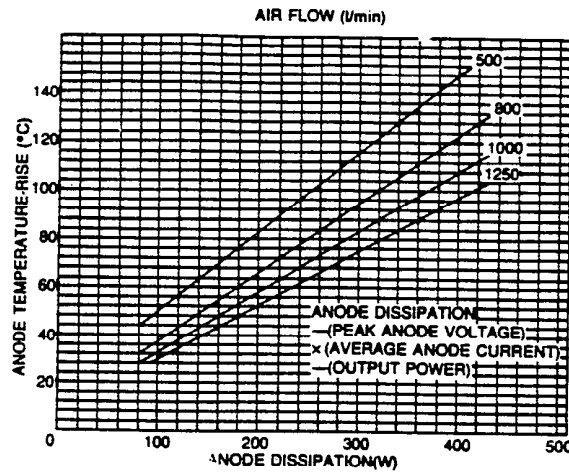

(Increase of anode temperature above inlet air temperature, T , as a function of anode dissipation, W , Anode dissipation = (peak anode voltage) \times (average anode current) - (output power))

9. PRESSURE DROP VS. AIR FLOW

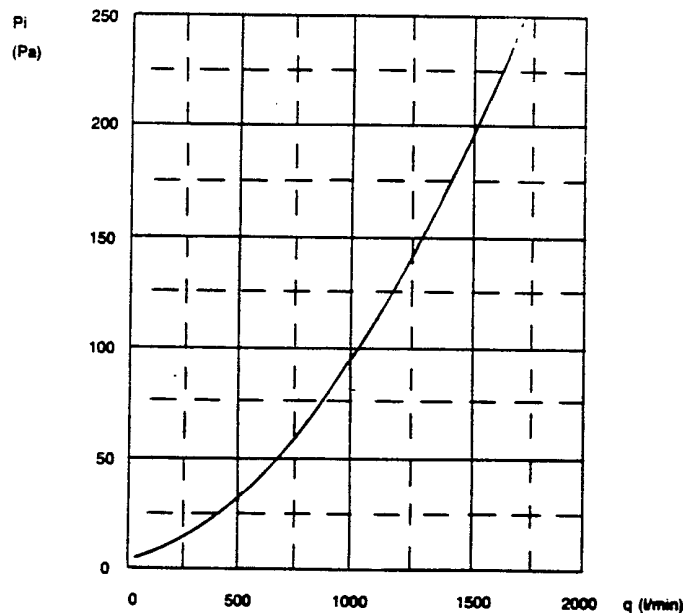

Pressure Drop P_i , across radiator as a function of air flow, q .

NATIONAL ELECTRONICS

A Division of Richardson Electronics, Ltd.

LaFox, IL 60147 • (708) 208-2300



2M107A-605
2M107A-795
2M107A-825

7/1/92 PAGE 8 OF 10

10. POWER SUPPLY CIRCUITS

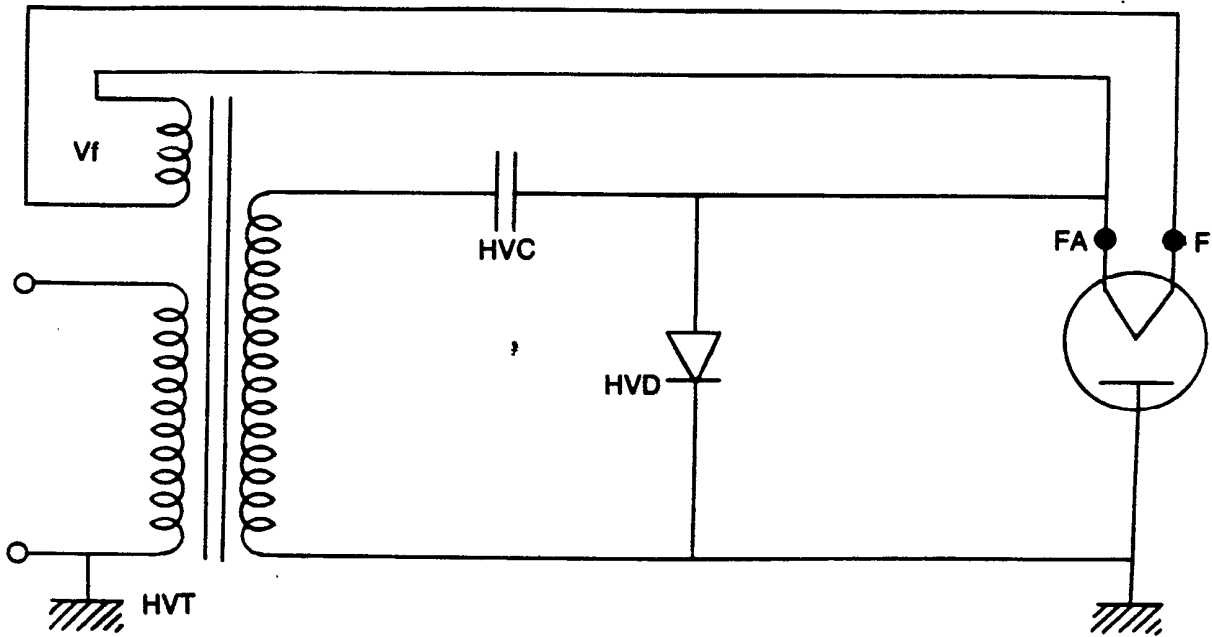

NATIONAL ELECTRONICS

A Division of Richardson Electronics, Ltd.
LaFox, IL 60147 • (708) 208-2300



NATIONAL

2M107A-605

2M107A-795

2M107A-825

7/1/92 PAGE 9 OF 10

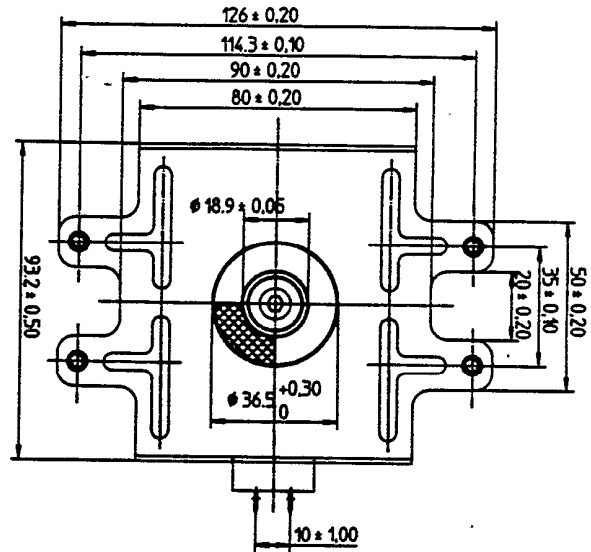
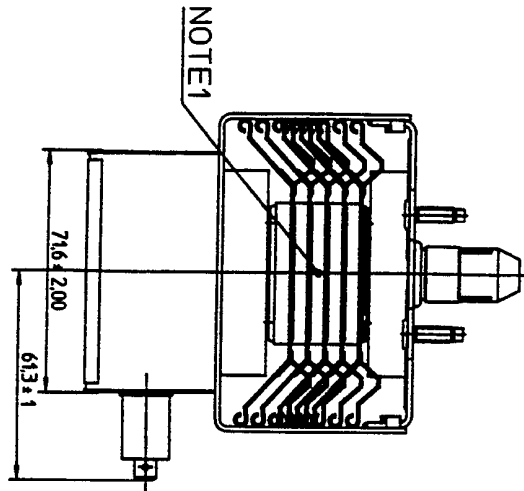

2M107A-825

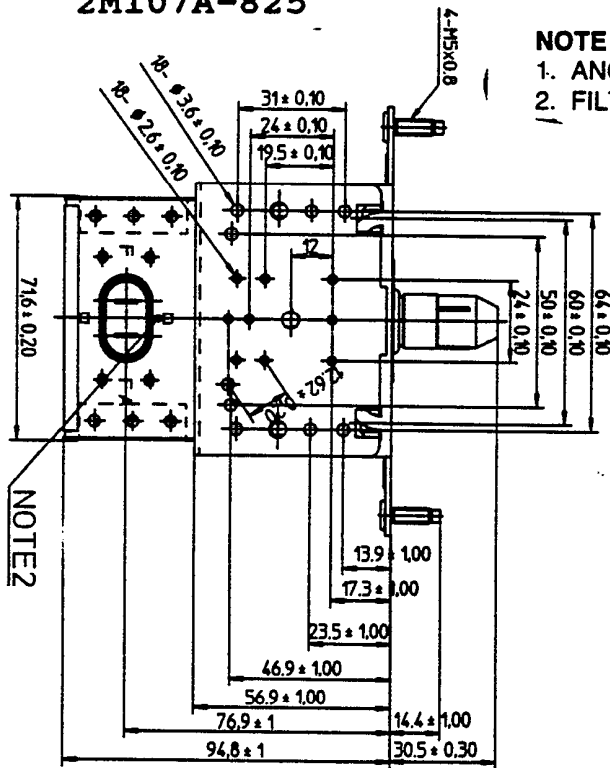

NOTE
 1. ANODE TEMPERATURE MEASURING POINT.
 2. FILTER BOX TEMPERATURE MEASURING POINT.

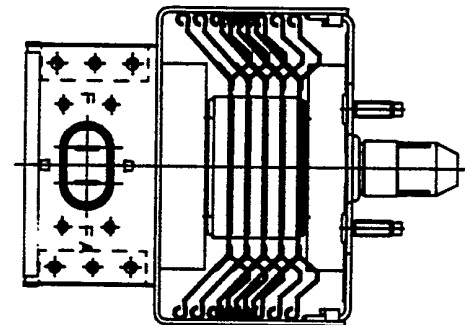

2M107A-795

NATIONAL ELECTRONICS

A Division of Richardson Electronics, Ltd.

LaFox, IL 60147 • (708) 208-2300



NATIONAL

**2M107A-605
2M107A-795
2M107A-825**

7/1/92 PAGE 10 OF 10

2M107A-605

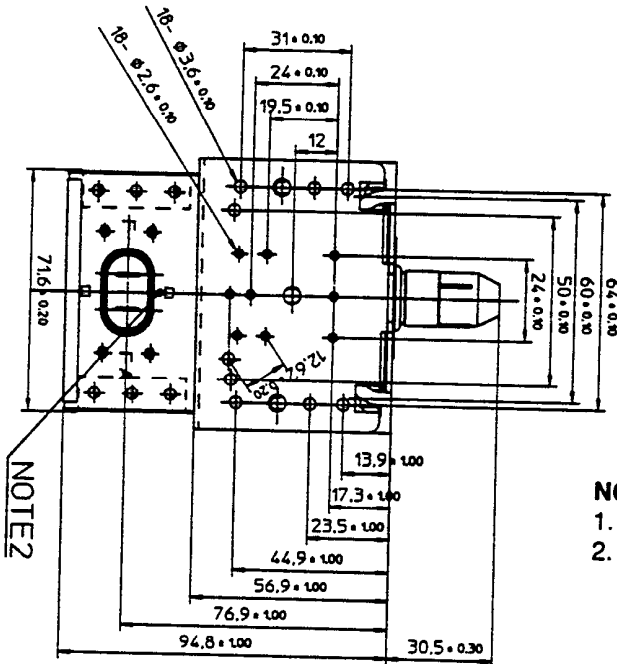
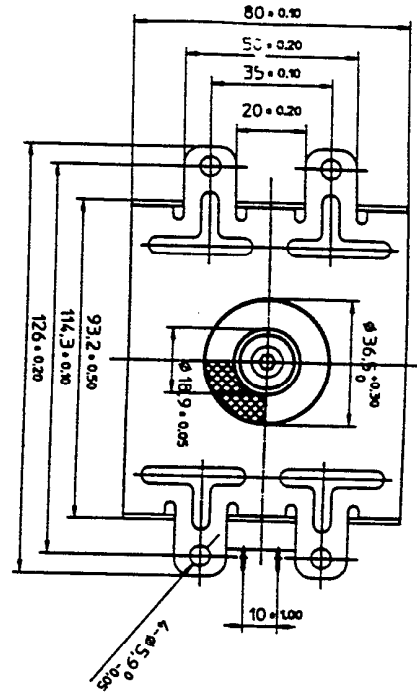
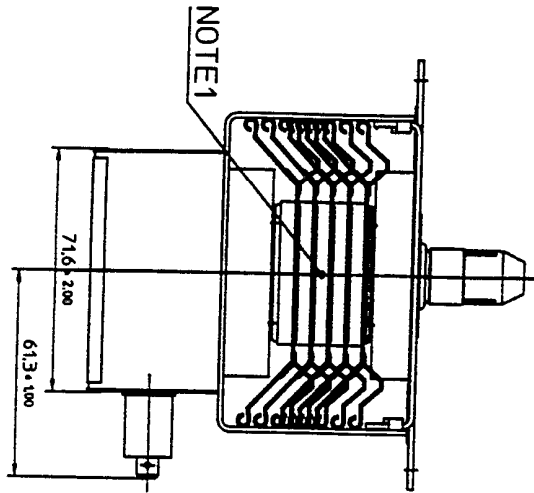

NOTE
1. ANODE TEMPERATURE MEASURING POINT.
2. FILTER BOX TEMPERATURE MEASURING POINT

NATIONAL ELECTRONICS

A Division of Richardson Electronics, Ltd.
LaFox, IL 60147 • (708) 208-2300